

KOM0002AX

PLUG-AND-SOCKET CONNECTOR LAYOUT

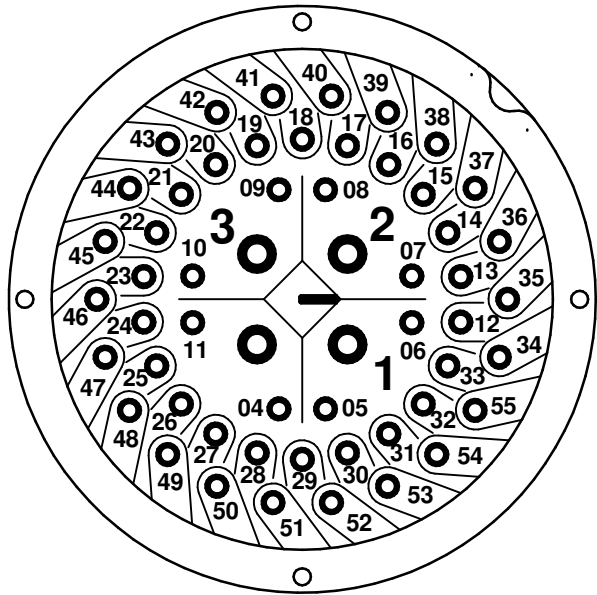

LEGENDS:

- M1** ELECTRIC MOTOR
- R1** RELAY OUTPUT No1 (SETTABLE)
- R2** RELAY OUTPUT No2 (SETTABLE)
- R3** RELAY OUTPUT No3 (SETTABLE)
- R4** RELAY OUTPUT No4 (SETTABLE)
- R5** RELAY OUTPUT No5 (SETTABLE)
- R6** RELAY OUTPUT No6 (SETTABLE)
- R7** RELAY OUTPUT No7 (SETTABLE)
- R8** RELAY OUTPUT No8 (SETTABLE)
- R9** RELAY OUTPUT No9 (SETTABLE)
- R10** RELAY OUTPUT No10 (SETTABLE)
- R11** RELAY OUTPUT No11 (SETTABLE)
- R12** RELAY OUTPUT No12 (SETTABLE)
- CS** CUSTOMER SUPPLY
- BS** BACKUP SUPPLY
- POSITIONER** POSITIONER IN/OUT ANALOG SIGNAL
- POSITIONER.LP** POSITIONER IN/OUT ANALOG SIGNAL. LOOP POWER
- MONIT.** MONITOR RELAY
- FIELDBUS** FIELDBUS CARD
- REMOTE** REMOTE INPUT CARDS
- ACTS** AUXILIARY CLOSE TORQUE SWITCH
- AOTS** AUXILIARY OPEN TORQUE SWITCH
- ACLS** AUXILIARY CLOSE LIMIT SWITCH
- AOLS** AUXILIARY OPEN LIMIT SWITCH
- IP1** VALVE MIDDLE TRAVEL POSITION SWITCH (No 1)
- IP2** VALVE MIDDLE TRAVEL POSITION SWITCH (No 2)
- IP3** VALVE MIDDLE TRAVEL POSITION SWITCH (No 3)
- IP4** VALVE MIDDLE TRAVEL POSITION SWITCH (No 4)
- CPT** CURRENT POSITION TRANSMITTER
- CTT** CURRENT TORQUE TRANSMITTER
- CPT.LP** CURRENT POSITION TRANSMITTER, LOOP POWER
- CTT.LP** CURRENT TORQUE TRANSMITTER, LOOP POWER
- CTS** CLOSE TORQUE SWITCH
- OTS** OPEN TORQUE SWITCH
- CLS** CLOSE LIMIT SWITCH
- OLS** OPEN LIMIT SWITCH
- TRM** THERMAL PROTECTION DEVICE (MOTOR WIND.)
- HT** ANTI-CONDENSATION HEATER
- BLK** BLINKER SWITCH
- POT** POTENTIOMETER (VALVE POSITION SIGNAL)
- CPT** CURRENT POSITION TRANSMITTER (VALVE POSITION SIGNAL)
- DSM** DIGITAL SWITCH MECHANISM (ELECTRONIC VALVE POSITION AND TORQUE SIGNALS)

NOTES:

1. THE TERMINAL PLAN SHOWS THE MULTI-TURN ELECTRIC ACTUATOR IN INTERMEDIATE POSITION, ACTUATOR CLOSSES VALVE CLOCKWISE.
2. SEE ACTUATOR USER MANUAL AND DATASHEETS FOR TECHNICAL DATA, PARAMETERS AND DESCRIPTION OF THE ACTUATOR ELECTRIC AND ELECTRONIC EQUIPMENT.
3. IF THE ACTUATOR IS CONFIGURED TO BYPASS THE MOTOR PROTECTION THERMOSTAT (TRM), THE ACTUATOR WILL NO LONGER COMPLY WITH THE ESSENTIAL SAFETY REQUIREMENTS.
4. THE USER MUST FIT A CLASS 10 OVERLOAD RELAY. THE RELAY MUST BE SIZED ACCORDING TO THE OVERCURRENT PROT. DEVICE SETTING VALUE FOR THE MOTOR.
5. REFER TO THE MOTOR DATA SHEET FOR THIS VALUE. THE OVERLOAD RELAY MUST BE SIZED TO ENSURE THAT IT TRIPS WITHIN 10 SECONDS IN A FAULT CONDITION.
6. THE USER MUST COMPLETE A RISK ASSESSMENT AND IMPLEMENT WHATEVER MEASURES ARE REQUIRED TO ENSURE THAT THE RESULTANT SYSTEM COMPLIES WITH ALL APPLICABLE LEGISLATION.

| PARAMETER | VALUE | DESCRIPTION |
|-----------------------------|-------|--|
| TYPE | K | MULTI-TURN ELECTRIC ACTUATOR WITH CENTRONIK (DIGITAL SWITCH MECH.) |
| MAIN POWER SUPPLY | 0 | AC THREE PHASE |
| EXTRA CARD No 1 | M | MODBUS-TCP |
| EXTRA CARD No2 | 0 | NO (WITHOUT) |
| MOTOR STARTER | 0 | REVERSIBLE CONTACTORS (STANDARD) |
| CUSTOMER SUPPLY & BLUETOOTH | 0 | 24VDC±20% AT MAX.POW.OUTPUT SW. |
| BACKUP SUPPLY & HEATER | 2 | NO BACKUP SUPPLY, HEATER INCLUDED |
| EXTRA SWITCH | A | VISUAL INDICATOR DISC (SEE NOTE 1) |

| ISSUE | | DATE | ISSUE | | DATE |
|-------|--------------------|----------|-------|---|------|
| A | FIRST RELEASE | 11-05-18 | 2 | - | - |
| 1 | PRODUCTION RELEASE | 18-02-20 | 3 | - | - |

| | | | | | | |
|-----------|------------|-------|---|--|--------|---------------|
| SHEET 1/2 | DATE | SIGN. | TERMINAL PLAN WD CXC-CKRC CTK, DSM, 3PH, MTCP, NOEX2, CTOR, CS24-IR, NOBK-HT, IMP | | FORMAT | DRAWING N° |
| MADE BY | 11-05-2018 | JB | | | A4 | KOM0002AX - 1 |
| CHECKED | 11-05-2018 | JP | | | | |
| APPROVED | 11/05/2018 | JP | | | | |

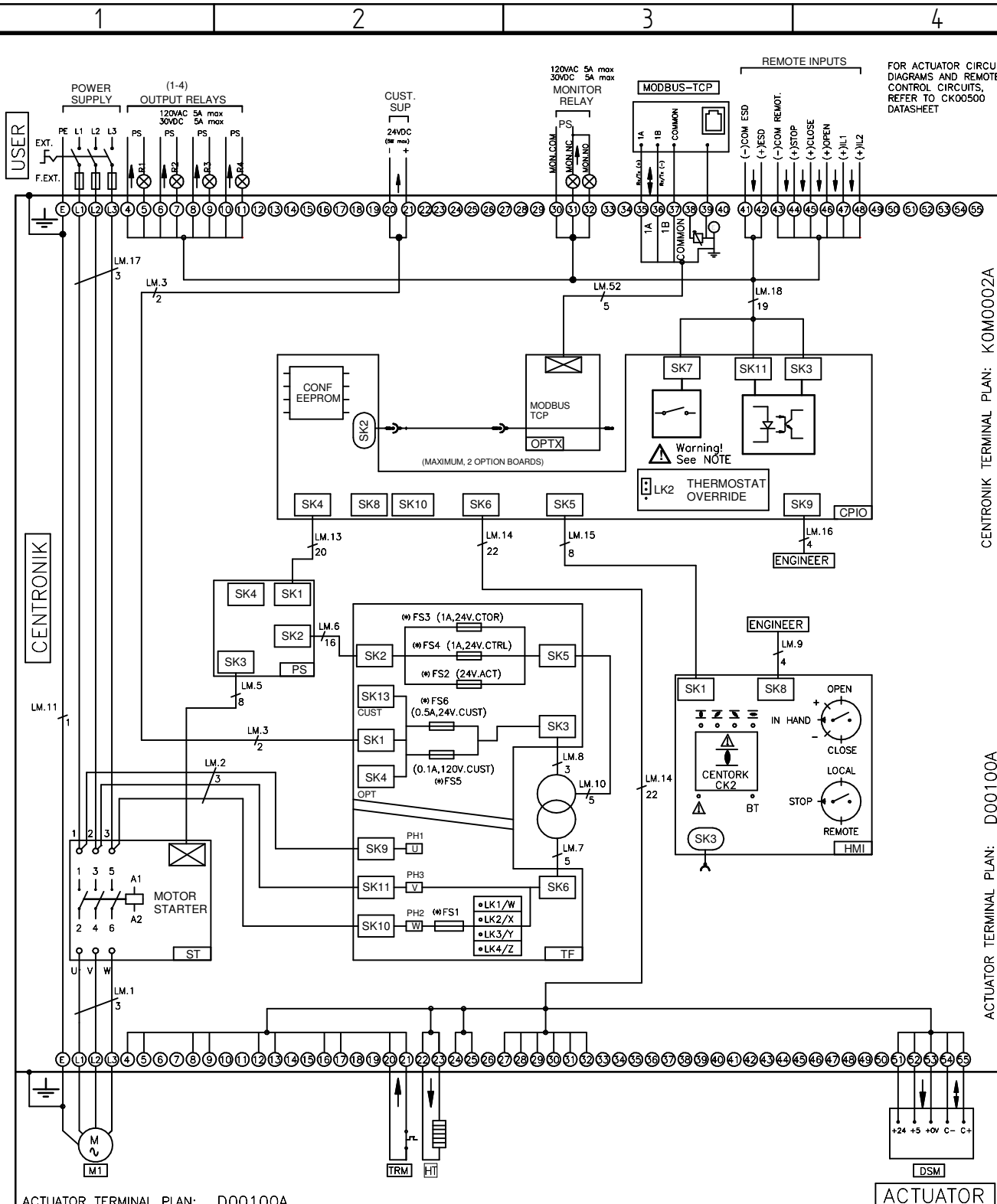

ACTUATOR TERMINAL PLAN: D00100A

WARNING: REFER TO SAFE USE AND INSTALLATION MANUAL OR CK00500 DATASHEET FOR APPROVED FUSES.

FS1: ACCORDING TO THE POWER SUPPLY VOLTAGE 110VAC/115VAC: FS1 (0,5 A) ANY OTHER VOLTAGE: FS1 (0,25 A)

THE TERMINAL PLAN SHOWS THE MULTI-TURN ELECTRIC ACTUATOR IN INTERMEDIATE POSITION, ACTUATOR CLOSES VALVE CLOCKWISE. REFER TO SAFE USE AND INSTALLATION MANUAL AND DATASHEETS FOR TECH. DATA, PARAMETERS AND DESCRIPTION OF THE ACTUATOR ELECTRIC AND ELECTRONIC EQUIPMENT. ACTUATORS WITH SOLID STATE STARTER (SSS), THE ACTUATOR MUST BE PROTECTED USING SUITABLE RATED HIGH SPEED SEMI-CONDUCTOR FUSES ON THE INCOMING SUPPLY IF THE ACTUATOR IS CONFIGURED TO BYPASS THE MOTOR PROTECTION THERMOSTAT (TRM), THE ACTUATOR WILL NO LONGER COMPLY WITH THE ESSENTIAL SAFETY REQUIREMENTS. THE USER MUST CONDUCT A RISK ASSESSMENT, AND IMPLEMENT WHATEVER EXTRA SAFETY MEASURES ARE REQUIRED, TO ENSURE THAT THE RESULTANT SYSTEM COMPLIES WITH THE LOW VOLTAGE DIRECTIVE, AND ANY OTHER LEGISLATION IN FORCE AT THE INSTALLATION SITE.

TRANSFORMER TAPPING OPTIONS

| TAP | | PRIMARY TAP NOMINAL VOLTAGE (VAC 50/60Hz) | | |
|-----|---|---|-----|-----|
| | | LV | EU | HV |
| LK1 | W | 110/115/120 | 380 | 460 |
| LK2 | X | 220/230 | 400 | 480 |
| LK3 | Y | 240 | 415 | 500 |
| LK4 | Z | n/a | 440 | 600 |

| ISSUE | DATE | ISSUE | DATE |
|-------|--------------------|----------|------|
| A | FIRST RELEASE | 11-05-18 | 2 |
| 1 | PRODUCTION RELEASE | 18-02-20 | 3 |

| | | | | | |
|-----------|------------|-------|---|---|-------------|
| SHEET 2/2 | DATE | SIGN. | WIRING DRAWING | This drawing and the information it contains are property of Rotork Controls Limited, and they will not be reproduced or disclosed, in whole or in part, without the prior written consent of Rotork. | |
| MADE BY | 11-05-2018 | JB | WD CKC-CKRC CTK, DSM, 3PH, MTEP, NOEX2, CTOR, CS24-IR, NOBK-HT, IMP | | |
| CHECKED | 11-05-2018 | JP | | FORMAT | DRAWING N° |
| APPROVED | 11/05/2018 | JP | | A4 | KOM0002AX-1 |

CENTRONIK TERMINAL PLAN: KOM0002A

ACTUATOR TERMINAL PLAN: D00100A

A

B

C

D

E

F